

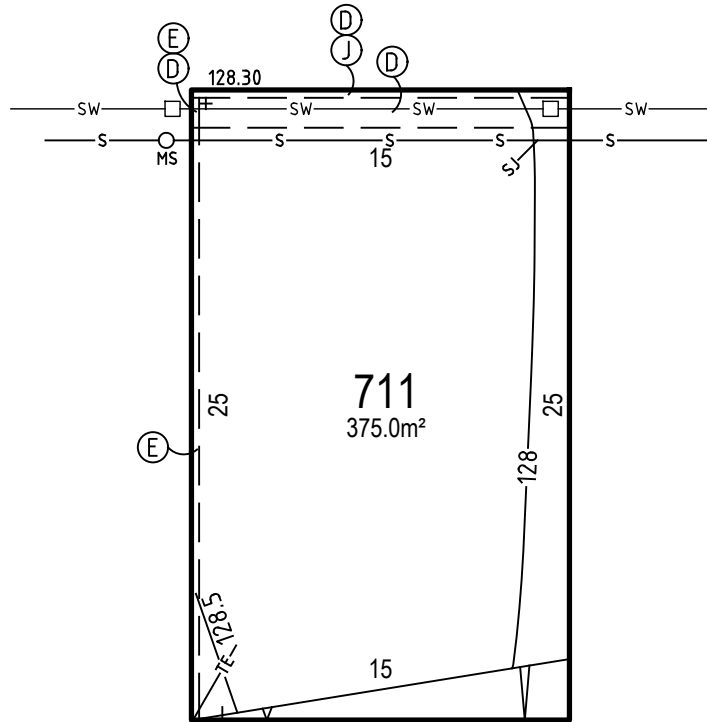

# GREGORY HILLS





## LOT 711



JERVIS

STREET

### LEGEND

- TEG— ELECTRICITY, TELECOMMUNICATIONS & GAS
- TE— TELECOMMUNICATIONS & ELECTRICITY
- S— SEWER —SJ— SEWER JUNCTION ○ MS MAINTENANCE SHAFT ○ SAC MANHOLE
- W— WATER
- sw— STORMWATER  GRATED PIT & LINTEL
- 4.7— CONTOUR +47.00 POINT HEIGHT  BATTER AT 1:6 (V:H) GRADE
- ELP ELECTRIC LIGHT POLE EP■ ELECTRICAL PILLAR  BAL BUSHFIRE ATTACK LEVEL
-  COUNCIL STREET TREE SUBJECT TO LANDSCAPING DESIGN & COUNCIL APPROVAL TO BE LOCATED FOLLOWING DRIVEWAY CONSTRUCTION

0 5 10 15

- Ⓧ EASEMENT TO DRAIN WATER 1.5 WIDE
- Ⓧ EASEMENT FOR SUPPORT 0.3 WIDE
- Ⓧ EASEMENT FOR SUPPORT 0.3 WIDE (DP1211730)

The material herein is intended as a guide only. No liability for negligence or otherwise is assumed by Dart West, its principals or its servants or its agents. No material contained herein shall form the basis of or be part of any agreement and no warranty is given or implied as to the accuracy of the whole or any part of the material. Prospective buyers should not rely solely on this material but should make their own enquiries at the Gregory Hills Land Sales and Information Centre or contact us on (02) 46485511.